

800-CT8-LP current measuring module

Expansion module for
basic devices of the 800 series

User manual and technical data





Suitable base devices and number of module slots:

Suitable base devices / Number of free slots	Slot assignment of an 800-CT8-LP module on the basic device
UMG 801 (from FW 1.7.3) / 12 slots + 1 slot for an additional 800-DI14 module	1 slot
UMG 800 (from FW 1.7.1) / 12 slots + 1 slot for an additional 800-DI14 module	1 slot
For more information on module slot combinations and JanBus system limits, refer to the respective user manual for the base unit.	

Tab. Suitable basic devices

800-CT8-LP current measuring module

(Suitable for basic devices of the 800 series)

Doc. no.: 2.053.093.1.b

Date: 04/2026

The German version is the original edition of the documentation

Subject to technical alterations.

The contents of our documentation have been compiled with great care and reflect the current state of the information available to us. Nonetheless, we wish to point out that updates of this document are not always possible at the same time as technical refinements are implemented in our products. Please see our website under www.janitza.com for the current version.

Please see our website under www.janitza.com for the current version.

Information about the GridVis software.

 Janipedia: wiki.janitza.de

 Tutorials: youtube.com/@gridvis

Table of contents

1. Information on the devices and the user manual	8
1.1 Disclaimer.....	8
1.2 Copyright notice.....	8
1.3 Technical changes.....	8
1.4 About this user manual.....	8
1.5 Defective device/disposal.....	9
2. Safety	10
2.1 Display of warning notices and safety information.....	10
2.2 Hazard levels.....	10
2.3 Product safety.....	10
2.4 Hazards when handling the device, components and modules.....	11
2.5 Electrically qualified personnel.....	12
2.6 Warranty in the event of damage.....	12
2.7 Safety information for handling current transformers.....	12
3. Product description	14
3.1 800-CT8-LP current measuring module.....	14
3.2 Incoming goods inspection.....	15
3.3 Intended use.....	15
3.4 Overview of module functions.....	15
3.5 EU/UKCA Declaration of Conformity.....	16
3.6 FCC Declaration of Conformity.....	16
3.7 Transformers.....	16
3.8 Scope of delivery.....	16
3.9 Operating concept.....	17
3.10 GridVis Power Grid Monitoring Software.....	17
4. Mounting	18
4.1 Mounting module.....	18
4.2 Checking the module's communication.....	21
4.3 Faulty module communication.....	21
5. Connections/controls	22
6. Module markings – rating plate	23

7. Installation	24
7.1 Current measurement with the module.....	24
7.2 Terminal assignment - schematic diagrams.....	24
7.2.1 Terminal 1 - connections 1-4.....	25
7.2.2 Terminal 2 - connections 5-8.....	25
7.3 Module identification / Diagnostics on the basic device.....	26
7.3.1 Entry Identify all modules.....	26
7.3.2 Entry Identify one module.....	27
7.3.3 Module identification - LED blink interval.....	27
8. Module communication / PC connection	28
8.1 Module communication.....	28
8.2 PC connection of the basic device with the current measuring module.....	28
8.2.1 Connection to a DHCP server and PC.....	28
8.2.2 PC direct connection to the basic device with current measuring module or your module series via the Ethernet interface.....	28
8.3 Module communication options.....	29
8.3.1 Module handling in the GridVis software.....	29
8.3.2 Basic device homepage.....	29
9. Operation, display and button functions of the basic device with module	30
9.1 Operation and button functions of the basic device with the 800-CT8-LP module.....	30
9.2 Module-relevant menu items of the basic device with 800-CT8-LP modules.....	30
10. Module-relevant configurations	34
10.1 LP current transformer configuration on the basic device.....	34
10.2 LP current transformer configuration in the GridVis software:.....	35
10.3 LP current transformer configuration via the device homepage of the basic device.....	36
11. Module-relevant measuring displays (module 800-CT8-LP only)	38
12. Device views	46
13. Technical data	47
13.1 Technical specifications.....	47
13.2 Performance characteristics of functions.....	49

14. Dismounting	50
15. Module exchange/error cases	52
15.1 Module replacement.....	52
15.2 Modules - Error cases.....	53
16. Service and maintenance	54
16.1 Repair.....	54
16.2 Service.....	54
16.3 Device adjustment.....	54
16.4 Calibration interval.....	54
16.5 Firmware update.....	54
16.6 Procedure in the event of a malfunction.....	54
16.7 Reset to factory settings	54
16.8 Information on saving measured values and configuration data.....	55

1. Information on the devices and the user manual

1.1 Disclaimer

Compliance with the usage information for the devices (modules/components) is a prerequisite for safe operation and attaining the stated performance characteristics and product features.

Janitza electronics GmbH assumes no liability for bodily injury, material damage or financial losses which result from disregard of the usage information.

Ensure that the usage information for the products is legible and accessible.

1.2 Copyright notice

© 2023 - Janitza electronics GmbH - Lahnau. All rights reserved.

Any reproduction, processing, distribution or other use of this usage information, in whole or in part, is prohibited.

All trademarks and the rights arising from them are the property of the respective owners of these rights.

1.3 Technical changes

- Make sure that your device (modules/components) matches the user manual.
- This user manual applies to the 800-CT8-LP module. Separate validities and distinctions are marked.
- First make sure you have read and understood the usage information accompanying the product.
- Keep the usage information associated with the product available for the entire service life and pass it on to any possible subsequent users.
- Find out about device revisions and the associated modifications of the usage information associated with your product at www.janitza.com.

1.4 About this user manual

If you have questions, suggestions or ideas for improvement of the user manual, please let us know via email at: info@janitza.com.

INFORMATION

This user manual describes the 800-CT8-LP module for a suitable basic device (see “Tab. Suitable basic devices” on p. 2) and provides information about the operation of the devices and modules.

Also consult the additional usage information relevant for this user manual, such as:

- the installation manual.
- the data sheet.
- the "Safety information" supplement.
- the supplement on mounting the modules.
- the usage information on the basic device and the integrated modules of your meter and module topology.

Moreover, the **GridVis** software has an “online help” feature.

INFORMATION

Our usage information uses the grammatical masculine form in a gender-neutral sense! This form always refers equally to women, men and diverse. In order to make the texts more readable, distinctions are not made. We ask for your understanding for these simplifications.

1.5 Defective device/disposal

Before sending **defective devices, modules or components** back to the manufacturer for testing:

- Contact the manufacturer's Support department.
- Send devices, modules or components complete with all accessories.
- When doing so, please bear the terms for transportation in mind.

INFORMATION

Please return defective or damaged devices, modules or components to Janitza electronics GmbH in accordance with the shipping instructions for air or road freight (complete with accessories).

Observe special regulations for devices with built-in batteries or rechargeable batteries!

Do not attempt to open or repair the device (the module, the component) on your own because otherwise all warranty claims become invalid!

For the **disposal** of the device (the module, the component), please observe national regulations! Dispose of individual parts, as applicable, depending on their composition and existing country-specific regulations, e.g. as

- Electronic waste,
- Batteries and rechargeable batteries,
- Plastics,
- Metals.

Engage a certified disposal company to handle scrapping as needed.

Information on "Service and maintenance" of your device can be found in Sect. "16. Service and maintenance" on p. 54.

2. Safety

The chapter on Safety contains information which must be observed to ensure your personal safety and avoid material damage.

2.1 Display of warning notices and safety information

The warning notices shown below

- are found throughout the usage information.
- can be found on the devices themselves.
- indicate potential risks and hazards,
- underscore aspects of the information provided that clarifies or simplifies procedures.



This additional symbol on the device (module/component) itself indicates an electrical hazard that can lead to severe injury or death.



This general warning symbol draws attention to a possible risk of injury. Be certain to observe all of the information listed under this symbol in order to avoid possible injury or even death.



2.2 Hazard levels

Warning and safety information is marked by a warning symbol, and the hazard levels are shown as follows, depending on the degree of hazard:

DANGER
Warns of an imminent danger which, if not avoided, results in serious or fatal injury.
WARNING
Warns of a potentially hazardous situation which, if not avoided, could result in serious injury or death.
CAUTION
Warns of an immediately hazardous situation which, if not avoided, can result in minor or moderate injury.
ATTENTION
Warns of an immediately hazardous situation which, if not avoided, can result in material or environmental damage.

INFORMATION

Indicates procedures in which there is **no** hazard of personal injury or material damage.

2.3 Product safety

The devices, components and modules reflect current engineering practice and accepted safety standards, but hazards can arise nonetheless.

Observe the safety regulations and warning notices. If notices are disregarded, this can lead to personal injury and/or damage to the product.

Every type of tampering with or use of the devices and the modules,

- which goes beyond the mechanical, electrical or other operating limits can lead to personal injury and/or damage to the product;
- constitutes “misuse” and/or “negligence” under the product’s warranty and thus voids the warranty for any possible resulting damage.

Read and understand the user manual and the usage information on the basic device before installing, operating, maintaining and using the devices, components and modules.

Only operate the devices, components and modules when they are in perfect condition and in compliance with this user manual and the usage information that is included. Send defective devices, components or modules back to the manufacturer in compliance with proper transport conditions.

Retain the user manual throughout the service life of your product and keep it at hand for consultation.

When using the device, component or module, also observe the legal and safety regulations for your system that are applicable for the respective use case.

2.4 Hazards when handling the device, components and modules

When operating electric devices, components or modules, it is unavoidable for certain parts of these devices to conduct hazardous voltage. Consequently, severe bodily injury or material damage can occur if they are not handled properly.

Therefore, when handling our devices, components, or modules, always observe the following:

- Do not exceed the limit values specified in the user manual and on the rating plate! This must also be observed during testing and commissioning!
- Take note of the safety and warning notices in all usage information that belongs to the device, components or modules!

WARNING

Disregarding the connection conditions of the Janitza measurement devices, modules or components can lead to injuries or even death or to material damage!

- Do not use Janitza meters, modules or components for critical switching, control or protection applications where the safety of persons and property depends on this function.
- Do not carry out switching operations with the Janitza measurement devices, modules or components without prior inspection by your system manager with specialist knowledge! In particular, the safety of persons, material assets and the applicable standards must be taken into account!

WARNING

Risk of injury due to electrical current and voltage!

Severe bodily injury or death can result! Therefore please abide by the following:

- **Do not touch bare, stripped wires or device inputs that are dangerous to touch on the devices, components and modules.**
- **Switch off your installation before commencing work! Secure it against being switched on! Check to be sure it is de-energized! Ground and short circuit! Cover or block off adjacent live parts!**
- **During operation and troubleshooting (especially with DIN rail devices), check the environment for dangerous voltages and switch these off if necessary!**
- **Wear protective clothing and protective equipment in accordance with applicable guidelines when working on electrical systems!**
- **Before making connections, ground the device / component / module by means of the ground wire connection, if present!**
- **Do not touching bare or stripped leads that are energized! Equip stranded conductors with wire ferrules!**
- **Hazardous voltages can be present in all circuitry parts that are connected to the power supply.**
- **Protect wires, cables and devices with a suitable line circuit breaker/fuse!**
- **Never switch off, remove or tamper with safety devices!**
- **There can still be hazardous voltages present in the device or in the component (module) even after it has been disconnected from the supply voltage (capacitor storage).**
- **Only connect screw terminals with the same number of poles and design!**
- **Do not exceed the limit values specified in the user manual and on the rating plate! This must also be observed during testing and commissioning.**
- **Take note of the safety and warning notices in the usage information that belongs to the device, components or modules!**

2.5 Electrically qualified personnel

To avoid bodily injury and material damage, only electrically qualified personnel are permitted to work on the devices and their components, modules, assemblies, systems and current circuits who have knowledge of:

- The national and international accident prevention regulations.
- Safety technology standards.
- Installation, commissioning, operation, disconnection, grounding and marking of electrical equipment.
- The requirements concerning personal protective equipment.

Electrically qualified persons within the scope of the technical safety information of all usage information associated with the device and its components (modules) are persons who can furnish proof of qualification as an electrically skilled person.

WARNING

Warning against unauthorized manipulation or improper use of the device or its components (modules)!

Opening, dismantling or unauthorized manipulation of the device and its components (modules) which goes beyond the mechanical, electrical or other operating limits indicated can lead to material damage or injury, up to and including death.

- **Only electrically qualified personnel are permitted to work on the devices and their components (modules), assemblies, systems and current circuits.**
- **Always use your devices or components (modules) only in the manner described in the associated usage information.**
- **If there is discernible damage, send the device or the component (module) back to the manufacturer!**

2.6 Warranty in the event of damage

Any unauthorized tampering with or use of the device, component or module constitutes "misuse" and/or "negligence" under the product's warranty and thus voids the warranty for any possible resulting damage. Note in this regard Sect. "3.3 Intended use" on p. 15.

2.7 Safety information for handling current transformers

The field of transformer technology groups the totality of all devices that perform the function of a current, voltage or measuring transformer together as **sensors**.

In the usage information for our devices, modules and components, the terms **current transformer**, **voltage transformer** or **transformer** all refer to **sensors**.

A further distinction is drawn between the terms **current transformer (CT)** and **low-power current transformer (LP-CT)** :

The term "current transformer" is used for special transformers for the primary-proportional conversion of currents of large magnitudes to directly measurable, smaller current values.

In contrast, the term "LP current transformer" (low-power current transformer) is used for special transformers for the primary-proportional conversion of currents of large magnitudes to directly measurable, smaller voltage values (low power).

Current transformers and **LP current transformers** provide safe galvanic isolation between the primary circuit and the measurement circuit due to their design and their physical operating principle. For Janitza measurement devices, modules and components, use only "**transformers for measuring purposes**" which are suitable for the energy monitoring of your system! Observe the corresponding warning notices (see Sect. "7.1 Current measurement with the module" on p. 24)!

Basic devices use only the term "**current transformer**" in the display for the configuration of both **current transformers** and **LP current transformers**.

⚠ CAUTION**Risk of injury or damage to the meter due to high measured currents/measured voltages at the connections of the current transformers!**

High measurement currents can cause temperatures of up to 80 °C (176 °F) on the connections of the current transformers

- **Use wiring that is designed for an operating temperature of at least 80 °C (176 °F)!**
- **Only use current transformers with basic insulation to IEC 61010-1:2010!**
- **Make sure that screw terminals for the current transformer connection on the device are adequately tightened!**
- **Comply with the information and provisions in the documentation of your current transformers!**
- **Ground connections present on the secondary windings of the current transformers must be connected to ground!**
- **The current transformers can be hot even after the power supply has been switched off. Allow the connections of the current transformers and the connecting cables to cool down before touching them!**

⚠ CAUTION**Risk of injury or damage to the basic device (module) and/or your system due to a short circuit!**

Inadequate insulation at the current measurement inputs of the modules with respect to the supply circuits of the basic device can cause dangerous voltages at the measurement input or damage to your device (module)/system.

- **Ensure reinforced or double insulation with respect to the supply circuits!**

3. Product description

3.1 800-CT8-LP current measuring module

The current measuring module

- is suitable for basic devices of the 800 series (see "Tab. Suitable basic devices" on p. 2).
- extends the functional range of the basic device to include additional current measuring channels (2 groups of 4 current measuring channels each);
- is suitable for low-power current transformers with a secondary voltage of 0 .. 400 mV.

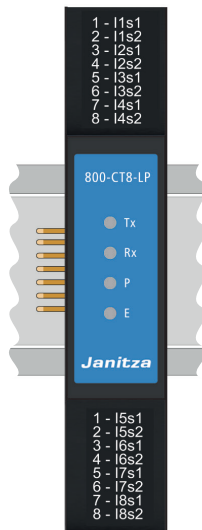

Fig.: Module 800-CT8-LP
(view without terminals)

The basic device (see "Tab. Suitable basic devices" on p. 2) with current measuring module measures current exclusively via low-power current transformers. The LP current transformers require double insulation in accordance with IEC 61010-1:2010 for the nominal voltage of the circuit.

Please refer to the definition of the terms "current sensors", "current transformers" and "low-power current transformers" on Page 12 in this user manual!

⚠ WARNING

Damage to the device/module or your installation even including life-threatening injuries due to a short circuit.

Insufficient insulation of the equipment (LP current transformers) at the current measurement inputs with respect to the circuits can lead to life-threatening voltages or damage to your device, module or system.

- **Observe the information and specifications for your LP current transformer concerning insulation and ensure end-to-end double insulation of your LP current transformers to mains and measuring circuits!**

ℹ INFORMATION

When setting up your meter and module topology, note the following:

- Do not exceed the permitted number of modules on a basic device (see usage information for the basic device and "Tab. Suitable basic devices" on p. 2).
- Check that the scope of delivery of the module includes the appropriate bus connector (JanBus interface) for connection to the basic device.
- In addition to the current measuring module, also read and understand the usage information for your basic device and the LP current transformers!
- Do not extend the connecting cables of the LP current transformers at the current measurement inputs of the device/module! Extended measuring leads can influence the measurement result!
- Do not exceed the maximum bus length of the JanBus (see Sect. "13. Technical data" on p. 47)!

3.2 Incoming goods inspection

The prerequisites for trouble-free and safe operation of the module include proper transport, storage, setup and assembly, as well as proper operation and maintenance.

Exercise due caution when unpacking and packing the device, do not use force and only use suitable tools. Check the following:

- the module by performing a visual inspection to ensure flawless mechanical condition.
- the scope of delivery (see Sect. "3.8 Scope of delivery" on p. 16) for completeness before beginning with assembly and installation.

If it must be assumed that safe operation of your basic device with module is not possible:

1. **Switch off the power to your system (your device)!**
2. **Secure it against being switched back on!**
3. **Check to be sure it is de-energized!**
4. **Ground and short circuit the system (device)!**
5. **Cover or block off adjacent live parts!**

Safe operation is impossible, if, for example, the basic device with module:

- has visible damage,
- no longer functions despite an intact power supply,
- was subjected to extended periods of unfavorable conditions (e.g. storage outside of the permissible climate thresholds without adjustment to the room climate, condensation, etc.) or transport stress (e.g. falling from an elevated position, even without visible external damage, etc.).

ATTENTION

Improper handling may cause damage to the module and result in material damage!

The contacts of the bus connectors (Janbus interface) can bend or break off and destroy the bus connector.

- Never touch or manipulate the contacts of the bus connector!
 - Never force the bus connector into the module!
- Please note **Sect. "4. Mounting" on p. 18 in this regard.**
- **When handling, transporting and storing the module, protect the contacts of the bus connector!**

3.3 Intended use

The module / component

- is only for use in the industrial sector.
- is intended as an expansion module for a basic device (see "Tab. Suitable basic devices" on p. 2) in switchboard cabinets and small distribution boards.
- must only be mounted with a basic device that is disconnected from the power supply (see „4. Mounting“ on page 18).

i INFORMATION

More information on certain functions of the basic device with modules can be found in the usage information of the basic device.

The basic device and the modules are not designed for installation

- In vehicles! Use of the basic device with modules in non-stationary equipment is considered an exceptional environmental condition and is only permissible by special agreement.
- In environments with harmful oils, acids, gases, vapors, dusts, radiation, etc.
- In potentially explosive environments.

3.4 Overview of module functions

Functions of the 800-CT8-LP module:

- 8 current measurement inputs (2 groups of 4)
- Measuring category 300 V CAT II.
- Nominal input signal 0 .. 400 mV, adjustable.
- Occupies 1 slot (module slot) of a basic device.

3.5 EU/UKCA Declaration of Conformity

Please see the EU/UKCA declarations of conformity posted at www.janitza.com for the laws, standards and directives applied by Janitza electronics GmbH for the devices. The EU/UKCA conformity of the device permits the marking CE/UKCA.

3.6 FCC Declaration of Conformity



The device

- complies with Part 15 of the FCC Rules for Class B digital devices (limits to protect against harmful interference in a residential installation).
- generates, uses and can radiate high-frequency energy
- can cause harmful interference to radio communications if not installed and used properly. There is no guarantee that interference will not occur in a particular installation.

If there is radio or television reception interference, which can be determined by turning the device on and off, proceed as follows:

- Align or reposition the receiving antenna.
- Increase the distance between the device and the radio/television receiver.
- Connect the device and the radio/television receiver in different circuits.
- if necessary, contact Janitza support or a radio/television technician.

Code of Federal Regulations, Title 47, Part 15, Subpart B - Unintentional Radiators.

3.7 Transformers

It is not permitted to use the outputs of Janitza measurement devices, components and modules for switching protective devices or protective relays! Use only "Current transformers for measuring purposes" for Janitza measurement devices, components and modules!

3.8 Scope of delivery

Quantity	Part. no.	Designation
1	5231234	800-CT8-LP module (current measuring module)
1	5231263	Accessory pack
1	3303892	Installation manual DE/EN
1	3303342	"Safety Information" supplement

Tab. Scope of delivery, 800-CT8-LP current measuring module

i INFORMATION

- The modules are supplied with the necessary connection terminals and bus connectors (JanBus interface) for connection to a basic device or other modules (accessory pack).
- Please refer to the delivery note for all options and design variants supplied.
- The GridVis Power Grid Monitoring Software is available at www.janitza.com and can be used to configure the basic device with modules and read out data for analysis (prerequisite: PC connection to the basic device).

3.9 Operating concept

Options to configure the basic device with current measuring module or to read measured values:

- Display and buttons on the basic device (user interface).
- GridVis Power Grid Monitoring Software.
- RS-485 interface or Ethernet interface.

The modules can be used to realize meter and module topologies with a flexible arrangement of the DIN rails. For the operation of the devices, components and modules integrated in your meter and module topology, please refer to the respective additional usage information.

INFORMATION

This user manual describes modules and provides information on operating the modules via a basic device.

Please refer to the user manual for the basic device for information on operating, configuring and reading out expansion modules.

The GridVis software has an online help with tutorials.

A list of parameters and Modbus addresses with data on your basic device with module is available for you as a download at www.janitza.com.

3.10 GridVis Power Grid Monitoring Software

With the GridVis software, you have the perfect tool for programming, reading out and visualizing measurement data (download at www.janitza.com).

Performance characteristics of the GridVis software

- Configuration of the basic device and the modules of your meter and module topology.
- Graphic display of measured values.
- Online help and tutorials.

Connections to the PC (GridVis software)

Information on connections for communication between the PC and the basic device (with modules) can be found in the usage information of the basic device.

4. Mounting

4.1 Mounting module

⚠ CAUTION

Disregard of the installation instructions may cause property damage or personal injury!

Disregard of the installation instructions may cause damage to your basic device with module or destroy it and/or may also result in personal injury.

- **In addition to the installation instructions for your module, also observe the installation instructions for your basic device, in particular the safety and warning information.**
- **Before installing modules**
 - **Disconnect the supply of power to the system!**
 - **Secure it against being switched on!**
 - **Check to be sure it is de-energized!**
 - **Ground and short circuit!**
 - **Cover or block off adjacent live parts!**
- **Operate the basic device that belongs to the 800-CT8-LP module only with a supply voltage of 24 V! Observe the technical specifications in the usage information for the basic device.**
- **Provide adequate air circulation in your installation environment and cooling, as needed, when the ambient temperatures are high.**
- **Return defective modules to Janitza electronics GmbH in accordance with the shipping instructions for air or road freight (complete with accessories).**
- **All usage information is available for download at www.janitza.com.**

i INFORMATION

System limits:

- The maximum bus length (JanBus) for the setup of measurement device and module topologies can be found in the "Technical data".
- If necessary, observe the installation manual for transfer modules when setting up decentralized measuring concepts.
- Before mounting, please check the number of suitable modules for your measurement device and module topology based on the respective usage information.
- When installing the device/module, ensure that there is sufficient space in the installation environment. Please also note the size of the connection terminals used!

The scope of delivery for the 800-CT8-LP module can be found in the Sect. "3.8 Scope of delivery" on p. 16. More information on certain functions of the basic device with modules can be found in the usage information of the basic device.

Observe the installation instructions for your basic device (e.g. check bus connector installation!) and mount the 800-CT8-LP module with the system de-energized as follows:

1. Press in the open bottom bolts on the rear of the module.

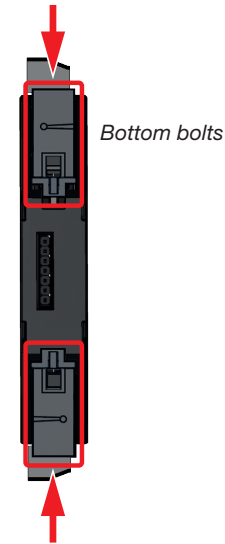

Fig.: Module rear view

i INFORMATION

- The following module assembly sequence must be observed!
- The illustrations may differ depending on the connection terminals used!

- If this has not yet been done, press the bus connector (JanBus interface) included in the scope of delivery into the sockets on the rear of your module.

ATTENTION

Improper handling may cause damage to the module and result in material damage!
 The contacts of the bus connectors (JanBus interface) can bend or break off and destroy the bus connector.

- **Never touch or manipulate the contacts of the bus connector!**
- **Never force the bus connector into the module!**
- **When handling, transporting and storing the module, protect the contacts of the bus connector!**

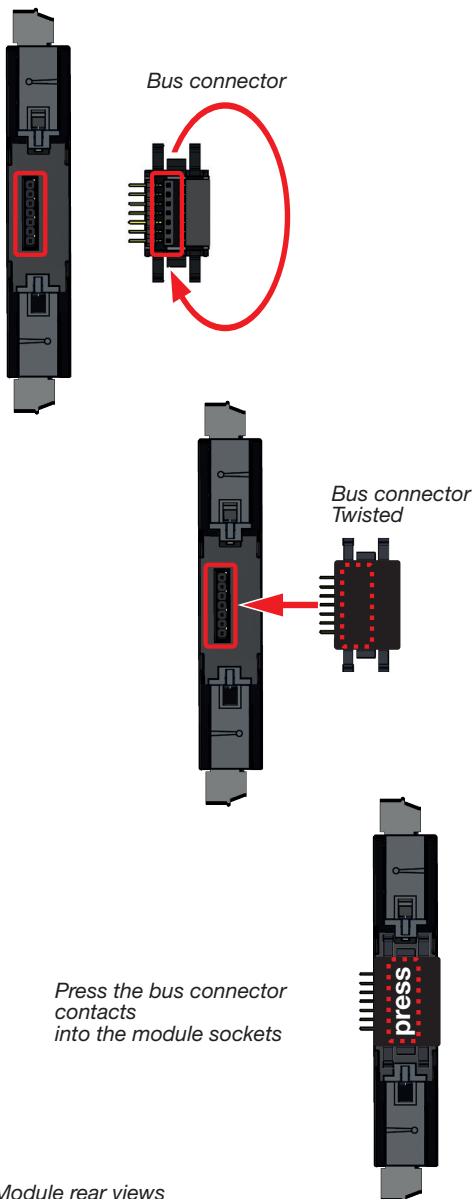

Press the bus connector contacts into the module sockets

Fig.: Module rear views

- Press the module with the bus connector onto the DIN rail (for suitable DIN rail types, see Sect. "13. Technical data" on p. 47) until the bottom bolts engage (click).

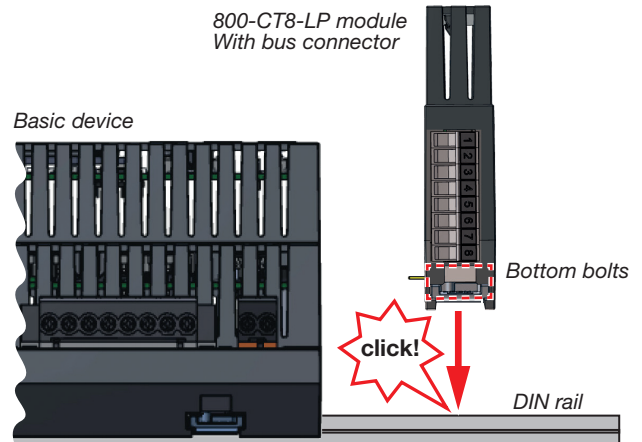

Fig.: Side view of basic device and 800-CT8-LP module

- To couple the bus connectors (devices), push the contacts of your module bus connector into the sockets of the basic device bus connector (or into the sockets of the connected module).

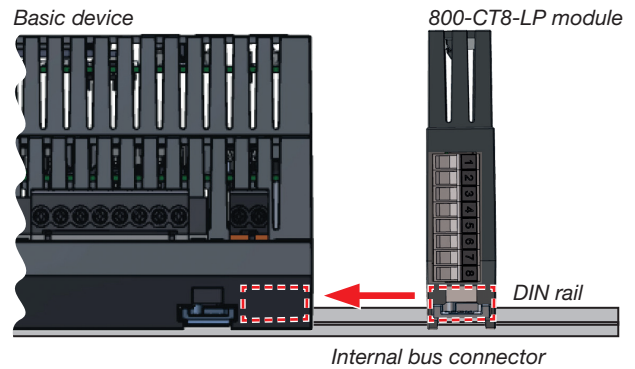

Fig.: Side view of basic device and 800-CT8-LP module



Fig.: Front view of the basic device, here a UMG 801 with coupled module 800-CT8-LP (Installation example - view without terminals)

5. After successfully coupling the bus connectors (of the devices), mount end brackets to the series of meters and modules.
6. Wire the module and apply power to the basic device (your system).
The basic device automatically recognizes the module during the power-up procedure!

i INFORMATION

Please note the following for the setup and dimensioning of your measurement device and module topology:

- 1 module of the type 800-CT8-LP has 8 current measuring channels with current measurements exclusively via low-power current transformers 0 - 400 mV.
- For remote series of measurement devices and modules, please note the maximum JanBus bus length (cable lengths) in the usage information for the transfer modules!
- Use end brackets to set up your measurement device and module series on the DIN rails.

4.2 Checking the module's communication

After installing your module, check the function of the communication between the basic device and the module using the display on the basic device (e.g. a UMG 801) as follows:

- When you are in the *Home* measuring display of the basic device, pressing the button 1 *ESC* takes you to the *Menu* window.
- Use buttons 2 (▲) and 5 (▼) to select the menu item *System information* and confirm with button 3 *Enter*.
- The *System information* window with the items *Basic device* and *Module 1* appears.

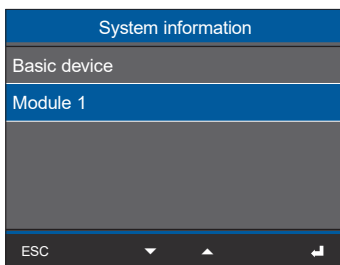

Fig.: System information window of a basic device with the entries "Basic device" and "Module 1".

- The basic device has detected module 1.

4.3 Faulty module communication

Error after starting the basic device with module:

i INFORMATION

The basic device does not recognize modules during the power-up procedure!

If there is no communication to modules, the module functions are not supported (e.g. current measurements).

- **Disconnect your system from the power supply and check the condition of the bus connectors and the connections of your modules to the basic device (JanBus interface). If necessary, push the contacts of the module bus connectors into the sockets of the basic device bus connector or the attached modules so that the bus connectors (devices) are coupled.**
- **For remote module series, check the connection of the transfer modules.**
- **If necessary, restart the basic device.**
- **If these measures do not lead to the desired result, please contact our Support – www.janitza.com**

5. Connections/controls

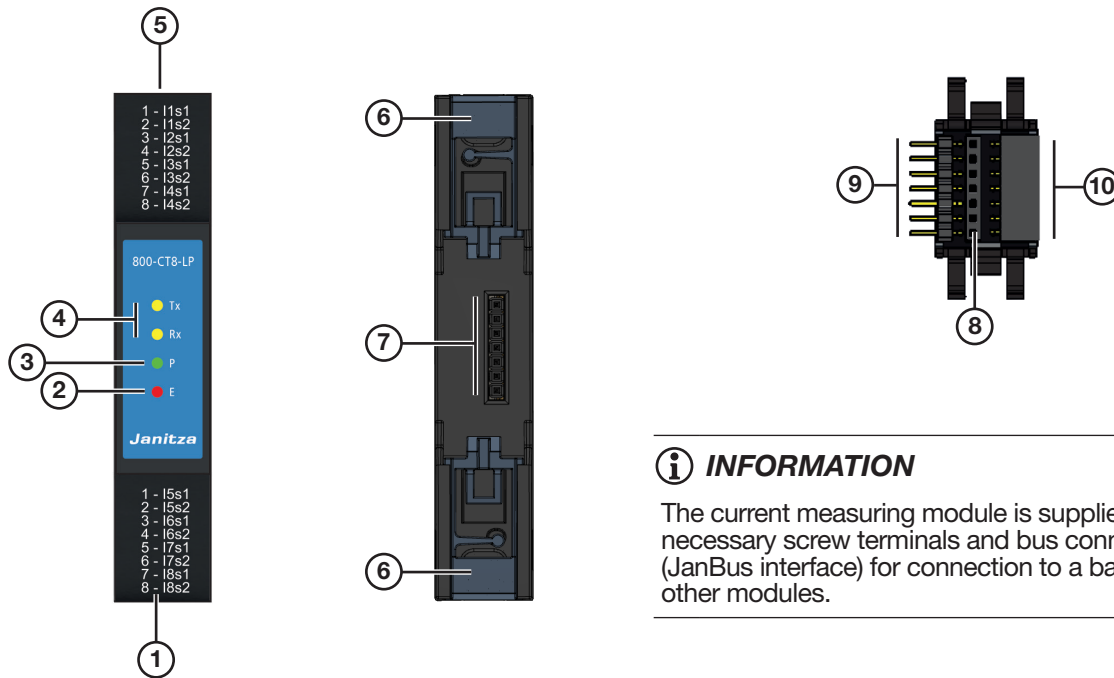

i INFORMATION

The current measuring module is supplied with the necessary screw terminals and bus connectors (JanBus interface) for connection to a basic device or other modules.

Item	Designation	Description
1	4 current measurement inputs in the group, terminals 1-8	Low-power current measurements I5, I6, I7, I8 (connection of the LP current transformers).
2	LED	Lights up "red" at power-up and remains so until completion of initialization (module not yet initialized). Then there is a switchover to cyclic data exchange (pos. 4).
3	LED	Lights "green" when the supply of power via the JanBus interface of the basic device is correct. The device is ready for operation.
4	2 LEDs	Blink "orange" during operation and indicate cyclic data exchange.
5	4 current measurement inputs in the group, terminals 1-8	Low-power current measurements I1, I2, I3, I4 (connection of the LP current transformers).
6	Bottom bolts	For mounting the module on the DIN rail.
7	JanBus interface	Connection contacts for the bus connector (item 8).
8	JanBus interface	Bus connector insert (sockets) into the module.
9	Bus connector contacts (JanBus)	Connection to a basic device (or connected modules).
10	Bus connector sockets (JanBus)	Connection of additional modules.

Tab. Connections/controls

6. Module markings – rating plate

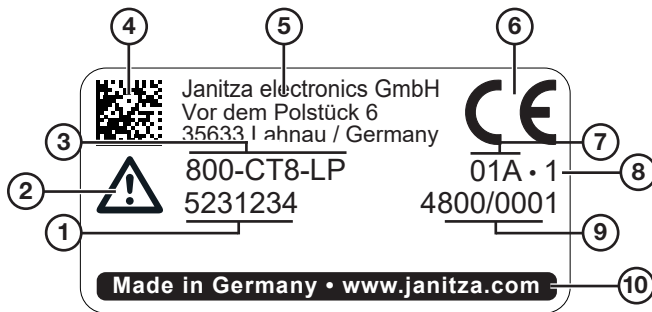

Item	Designation	Description
1	Part number	Marking for traceability.
2	Symbol for “Danger sign”	General hazard symbol. Be certain to observe the warning notices applied to the device and shown in the documentation in order to avoid possible injury or even death.
3	Device type	Device designation
4	DataMatrix code	Coded manufacturer data
5	Manufacturer	Complete contact address of the manufacturer (company name, street, house number, postal code, city, country).
6	CE conformity marking	See Sect. “3.5 EU/UKCA Declaration of Conformity” on p. 16
7	Manufacturer-specific data	Manufacturer data
8	Hardware version	Hardware version of the module
9	Type/serial number	Number for identification of the device
10	Designation of origin/web address	Country of origin and manufacturer’s web address

Tab. Identification of the module - rating plate

7. Installation

⚠ WARNING

Risk of injury due to high currents and high electrical voltages!

Severe bodily injury or death can result from:

- Touching bare or stripped leads that are energized.
- Inputs of devices, components and modules are dangerous to touch.

Therefore, please note for your system:

- **Disconnect the supply of power before starting work!**
- **Secure it against being switched on!**
- **Check to be sure it is de-energized!**
- **Ground and short circuit! Use the ground connection points with the ground symbol for grounding!**
- **Cover or block off adjacent live parts!**

⚠ CAUTION

Risk of injury or damage to the device due to high measurement currents at the connections of the current transformers or the current measurement inputs of the device!

High measurement currents can cause temperatures of up to 80 °C (176 °F) on the connections of the current transformers

- **Use wiring that is designed for an operating temperature of at least 80 °C (176 °F)!**
- **The current transformers can be hot even after the power supply has been switched off. Allow the connections of the current transformers and the connecting cables to cool down before touching them!**
- **Make sure that screw terminals for the current transformer connection on the device are adequately tightened!**
- **Ground connections present on the secondary windings of the current transformers must be connected to ground!**
- **Observe the general safety information for handling current transformers in section Sect. "2.7 Safety information for handling current transformers" on p. 12.**
- **Comply with the information and provisions in the usage information of your current transformers!**

7.1 Current measurement with the module

Your 800-CT8-LP module in combination with a basic device

- Measures current exclusively via low-power current transformers.
- Allows the connection of LP current transformers with a secondary voltage of 0 .. 333 mV for the current measurement inputs I1 to I8.
- Has a default setting for the LP current transformer ratios of 5 A/333 mV (I1 to I8).
- Does not measure DC currents.

7.2 Terminal assignment - schematic diagrams

i INFORMATION

The device and module illustrations may vary depending on the basic device and connection terminals used!

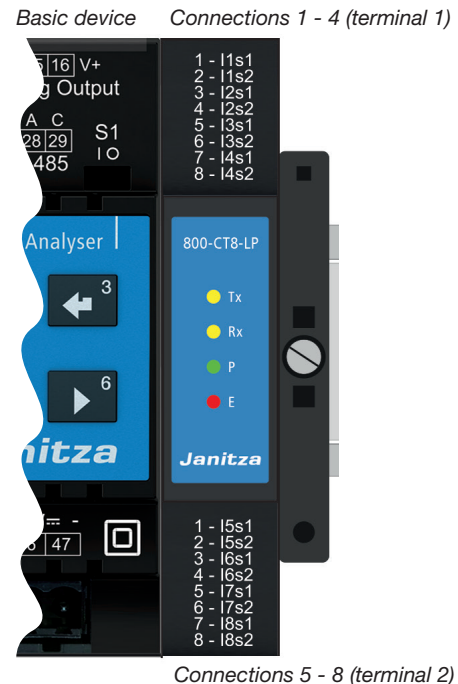
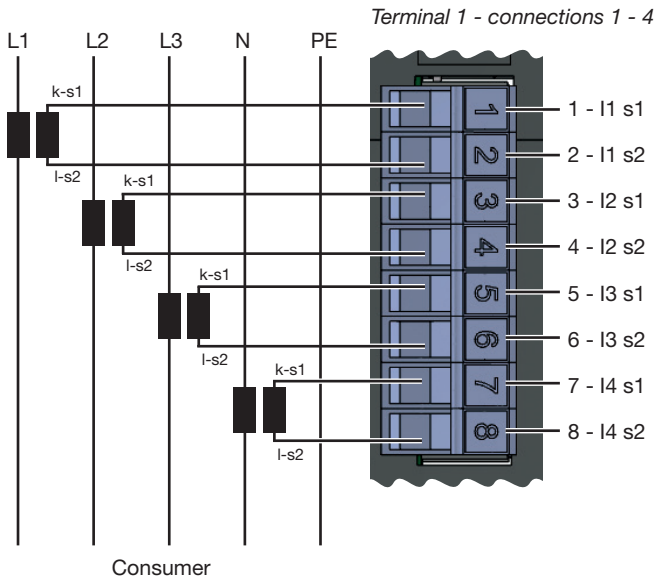

Fig. "Current measurement" connection variant with 800-CT8-LP module and terminal assignment.

7.2.1 Terminal 1 - connections 1-4



5-8

7.2.2 Terminal 2 - connections

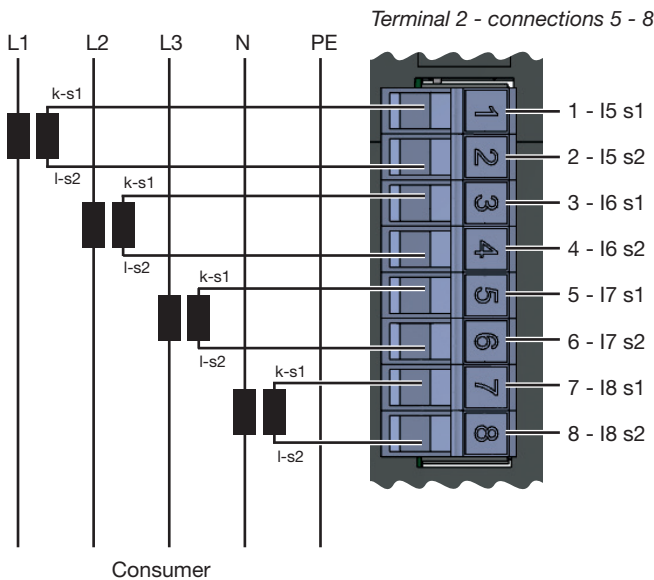

INFORMATION

You can configure the LP current transformer ratios via the user interface of the basic device, the device homepage or conveniently using the "Device configuration" function of the GridVis software.

Observe the following:

- For single measurements, the phase assignment of the current measuring channels is arbitrary. The measurement of system performance characteristics requires phase L1 - L3.
- The connection variants for current measurement in the usage information for the basic device

WARNING

Disregard of the connection conditions of the transformers to Janitza measurement devices or their components can lead to injuries or even death or to material damage!

- Do **not** use the outputs of the Janitza measurement devices or their components for switching protective devices or protective relays! Do **not** use **"Transformers for protection purposes"**!
- For Janitza measurement devices and their components use **only "Transformers for measurement purposes"** which are suitable for the energy monitoring of your system.
- Observe the information, regulations and limit values in the usage information on **"Transformers for measuring purposes"**, including during testing and commissioning of the Janitza measurement device, the Janitza component and your system.

7.3 Module identification / Diagnostics on the basic device

i INFORMATION

Before you start the module identification function (*Diagnostics* menu item) on the basic device, please make sure that the modules are mounted and connected correctly. Only correctly installed modules connected to the basic device guarantee the supply of power and data transmission.

The following descriptions are based on the example of the UMG 801 as the basic device. The illustrations and descriptions may differ for other basic devices.

The basic device provides the option of extending the range of functions using current measuring modules. The basic device automatically recognizes the module during the power-up procedure.

The Diagnostics menu item of the basic device is used to identify modules that are located at remote measurement points. After starting the module identification, the LEDs of the modules being searched for blink at an interval (see Sect. "7.3.3 Module identification - LED blink interval" on p. 27).

The module identification can be configured using the *Diagnostics* menu item of the basic device. Then proceed as follows:

- Press function button 1 *ESC* to open the menu.
- Use buttons 2 "▲" and 5 "▼" to select the menu item *Diagnostics* and confirm with button 3 *Enter*.
- The *Diagnostics* window appears.

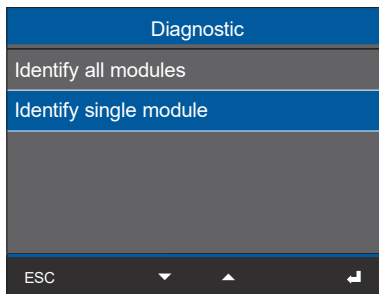

Fig. Window: *Diagnostics* with entries

- In the *Diagnostics* window, use keys 2 "▲" and 5 "▼" to select the entry *Identify all modules* or *Identify one module*. These mean:

Identify all modules	Simultaneously identifies all current measuring modules connected to a basic device.
Identify one module	Identifies one module from the module topology of your basic device.

7.3.1 Entry *Identify all modules*

- In the *Diagnostics* window, use buttons 2 "▲" and 5 "▼" to select the menu item *Identify all modules* and confirm with button 3 *Enter*.
- The window *Identify all modules* appears.

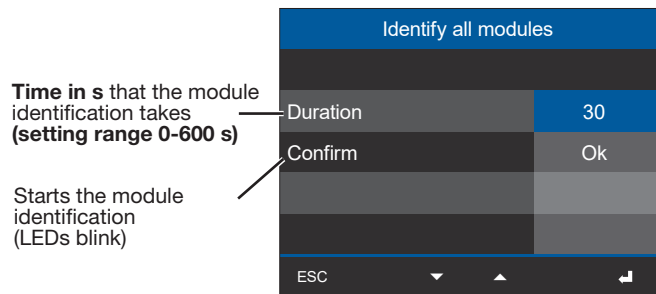

Fig. Window, *Identify all modules*

- In the *Identify all modules* window, use buttons 2 "▲" and 5 "▼" to select the menu item *Duration* and confirm with button 3 *Enter*.
- The first digit of the entry *Duration* blinks.
- Use buttons 4 (◀) and 6 (▶) to change the position of the digit to be set and buttons 2 (▲) and 5 (▼) to change the digit (-1/+1).
- Confirm your entries with key 3 *Enter*.
- Use keys 1 *ESC* and key 5 "▼" to access the entry *Confirm*.
- Press button 3 *Enter*.
- In the entry *Confirm*, *OK* blinks.
- Pressing button 3 *Enter* starts the identification of all modules using a blink interval of the LEDs (see Sect. "7.3.3 Module identification - LED blink interval" on p. 27).

7.3.2 Entry Identify one module

- In the *Diagnostics* window, use buttons 2 “▲” and 5 “▼” to select the menu item *Identify one module* and confirm with button 3 *Enter*.
- The *Identify one module* window appears.

Position of the module in the order of the basic device's module topology.

Time in s that the module identification takes (setting range 0-600 s)

Starts the module identification (LEDs blink)

Identify single module	
Module position	1
Duration	30
Confirm	Ok
ESC ▼ ▲ ↵	

Fig. Window: Identify one module

- In the *Identify one module* window, use keys 2 “▲” and 5 “▼” to select the menu item *Module position* and confirm with key 3 *Enter*.
- The entry *Module position* blinks.
- Use the keys 2 “▲” and 5 “▼” to enter the position number of the module to be identified (the position number depends on the number of modules connected in series to the basic device).
- Confirm the entry with key 3 *Enter*.
- Use keys 1 *ESC* and key 5 “▼” to access the entry *Duration*.
- Press button 3 *Enter*.
- The first digit of the entry *Duration* blinks.
- Use buttons 4 (◀) and 6 (▶) to change the position of the digit to be set and buttons 2 (▲) and 5 (▼) to change the digit (-1/+1).
- Confirm your entries with key 3 *Enter*.
- Use keys 1 *ESC* and key 5 “▼” to access the entry *Confirm*.
- Press button 3 *Enter*.
- In the entry *Confirm*, *OK* blinks.
- Pressing button 3 *Enter* starts the module identification with a blink interval of the LEDs on the corresponding module (see Sect. “7.3.3 Module identification - LED blink interval” on p. 27).

7.3.3 Module identification - LED blink interval

The module identification (diagnostics) procedure started on the basic device triggers a blink interval of the LEDs on the current measuring modules. The blink interval of the functions **Identify one module** and **Identify all modules** works the same way for a single module or for all modules!

LED status of the module in operation:

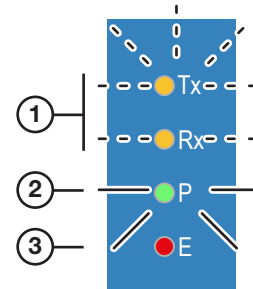

Item	Description
1	Blink "orange" during operation and signaling cyclic data exchange (Tx ... Transmit data, Rx ... Receive data).
2	Lights "green" if the supply of power via the JanBus interface of the basic device is correct, the device is ready for operation (P ... Power).
3	Lights "red" during initialization/startup and in the event of a fault (error). Note in this regard Sect. "15.2 Modules - Error cases" on p. 53.

LED status of the module during module identification:

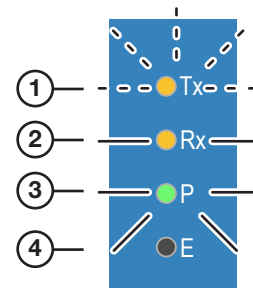

Item	Description
1	Blinks "orange" for the <i>Duration</i> of the module identification.
2	Lights "orange" for the <i>Duration</i> of the module identification.
3	Lights "green".
4	"Off"

i INFORMATION

During the **Duration of individual module identification**, the blink intervals of all other modules connected to the basic device are paused!

8. Module communication / PC connection

8.1 Module communication

Configure the current measuring module using the display and the buttons on the basic device.

The basic device connected to your module or module series uses an integrated **Ethernet interface** for communication with a PC.

To configure or read out the basic device with module or with your module series, the PC must have the GridVis software installed.

Another option for configuring modules or reading out measured values may be available via the device homepage of the basic device.

i INFORMATION

Further information on PC connections can be found in the respective user manual for the basic device.

8.2 PC connection of the basic device with the current measuring module

The PC connections of the basic device or your module series via the Ethernet interface are shown below using the UMG 801 as an example for other basic devices.

8.2.1 Connection to a DHCP server and PC

The DHCP server automatically assigns IP addresses to the basic device (with modules) and the PC.

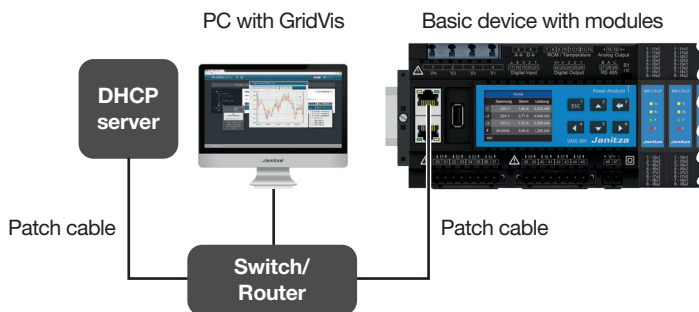

Fig. example: PC connection with DHCP server and PC

8.2.2 PC direct connection to the basic device with current measuring module or your module series via the Ethernet interface

The PC and basic device require a fixed IP address.

PC with GridVis

Basic device with modules

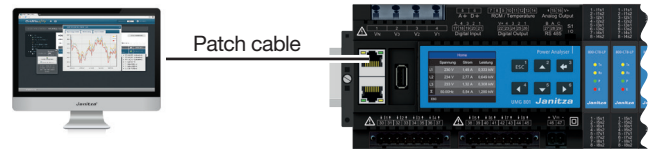

Fig. example: PC direct connection

Detailed descriptions of connection via the Ethernet interface can be found in the user manual for the basic device.

i INFORMATION

The figures described are examples! In conjunction with the basic device, there are numerous variants of topologies for devices and modules. Please refer to the usage information for the basic device and the modules of your devices and module topology.

8.3 Module communication options

8.3.1 Module handling in the GridVis software

The interface of the GridVis power grid monitoring software indicates in graphical form the modules connected to the basic device.

A user can configure various types of module handling in the GridVis software, including:

- Automatic module recognition
- Module addition at the end of the module topology of a basic device.
- Module addition within the module topology of a basic device.
- Module removal at the end of the module topology of a basic device.
- Module removal within the module topology of a basic device.
- Module swap.
- Module configuration swap (measurement).
- Data storage and data transfer.
- Swap out basic device.

A description of how to configure the modules in the GridVis software can be found in the online help or the tutorials for the software.

8.3.2 Basic device homepage

Another option for configuring modules or reading out measured values may be available via the device homepage of the basic device!

All further descriptions of a device homepage can be found in the usage information for the basic device.

9. Operation, display and button functions of the basic device with module

9.1 Operation and button functions of the basic device with the 800-CT8-LP module

The basic device with module has a display and function buttons to enable installation, commissioning and configuration without a PC.

i INFORMATION

- The configuration of your module and the display of module-relevant measurement data is carried out via the basic device.
 - Information on operation, the display and the button functions can be found in the usage information for the basic device.
 - The **GridVis** Power Grid Monitoring Software is available at www.janitza.com and can be used to configure your basic device with modules and read out data for analysis (prerequisite: PC connection to your basic device).
-

9.2 Module-relevant menu items of the basic device with 800-CT8-LP modules

The following illustrations and descriptions show module-relevant menu items in the measurement device display using the example of the UMG 801 as the basic device with the 800-CT8-LP modules.

The menu items in the measurement device display of the basic device

- include, for example with the UMG 801 as the basic device, up to 10 module entries with the respective position number, depending on the slot assignment. For additional basic devices, please refer to the maximum number of modules in “Tab. Suitable basic devices” on p. 2.
- Can be configured with your own measurement group name in the GridVis software (max. 255 characters).
- Appear in the title line as scrolling text depending on the text length.

Menu

- Home (start screen, 1st measuring display)
- Phasor diagram
 - Basic device 1-4
 - Basic device 5-8
 - **1. Module 1-4 (measurement group name)**
 - **1. Module 5-8**
 - ...
 - **10. Module 1-4**
 - **10. Module 5-8**
- Voltage
 - Voltage L-N
 - Voltage L-L
 - Voltage THD
- Current
 - Current
 - Basic device 1-4
 - Basic device 5-8
 - **1. Module 1-4**
 - **1. Module 5-8**
 - ...
 - **10. Module 1-4**
 - **10. Module 5-8**
 - THD-I
 - Basic device 1-4
 - Basic device 5-8
 - **1. Module 1-4**
 - **1. Module 5-8**
 - ...
 - **10. Module 1-4**
 - **10. Module 5-8**

Power

- Power summary
 - Basic device 1-4
 - Basic device 5-8
 - **1. Module 1-4**
 - **1. Module 5-8**
 - ...
 - **10. Module 1-4**
 - **10. Module 5-8**
- Active power
 - Basic device 1-4
 - Basic device 5-8
 - **1. Module 1-4**
 - **1. Module 5-8**
 - ...
 - **10. Module 1-4**
 - **10. Module 5-8**
- Reactive power
 - Basic device 1-4
 - Basic device 5-8
 - **1. Module 1-4**
 - **1. Module 5-8**
 - ...
 - **10. Module 1-4**
 - **10. Module 5-8**
- Apparent power
 - Basic device 1-4
 - Basic device 5-8
 - **1. Module 1-4**
 - **1. Module 5-8**
 - ...
 - **10. Module 1-4**
 - **10. Module 5-8**
- Power factor
 - Basic device 1-4
 - Basic device 5-8
 - **1. Module 1-4**
 - **1. Module 5-8**
 - ...
 - **10. Module 1-4**
 - **10. Module 5-8**

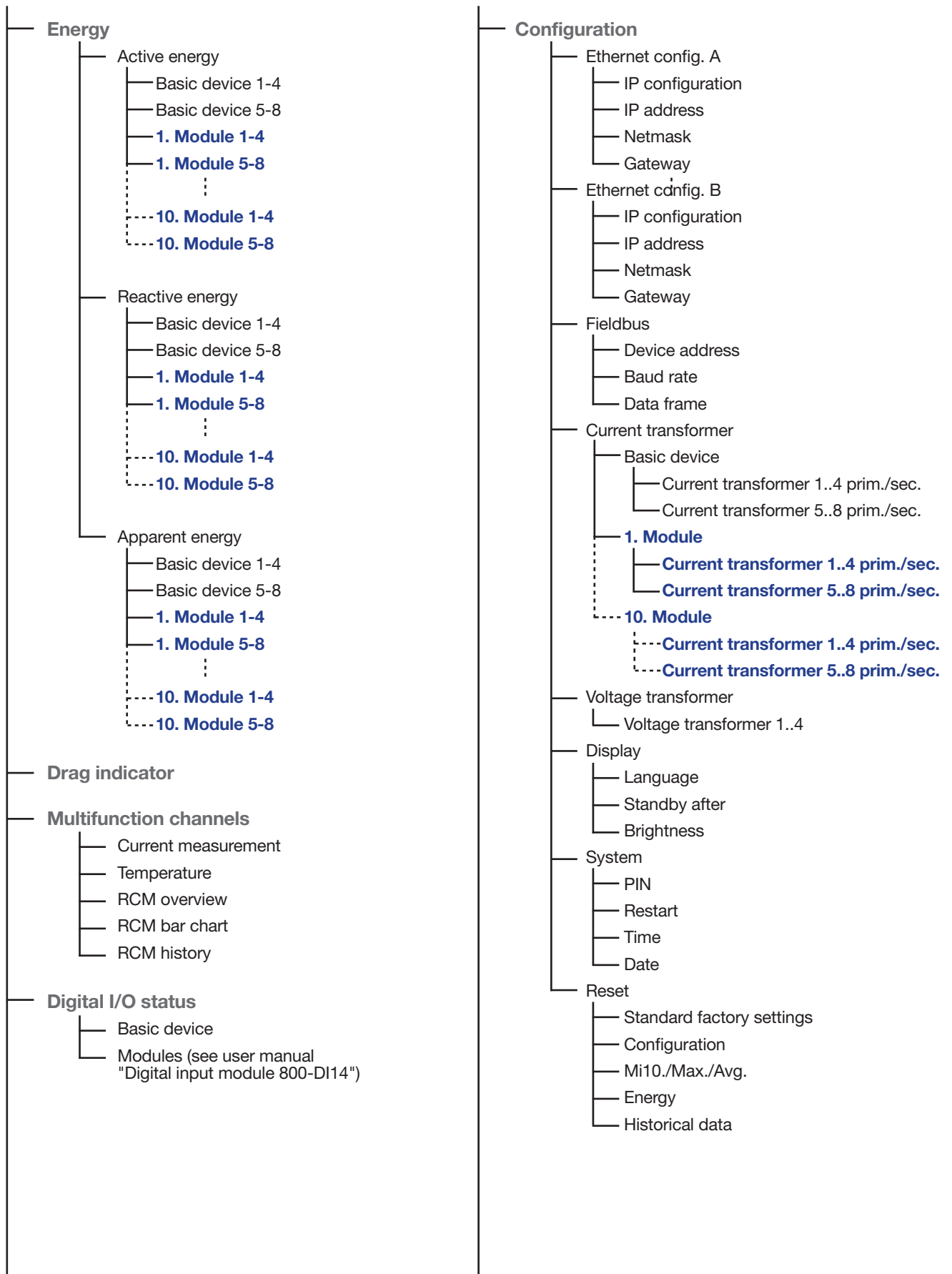

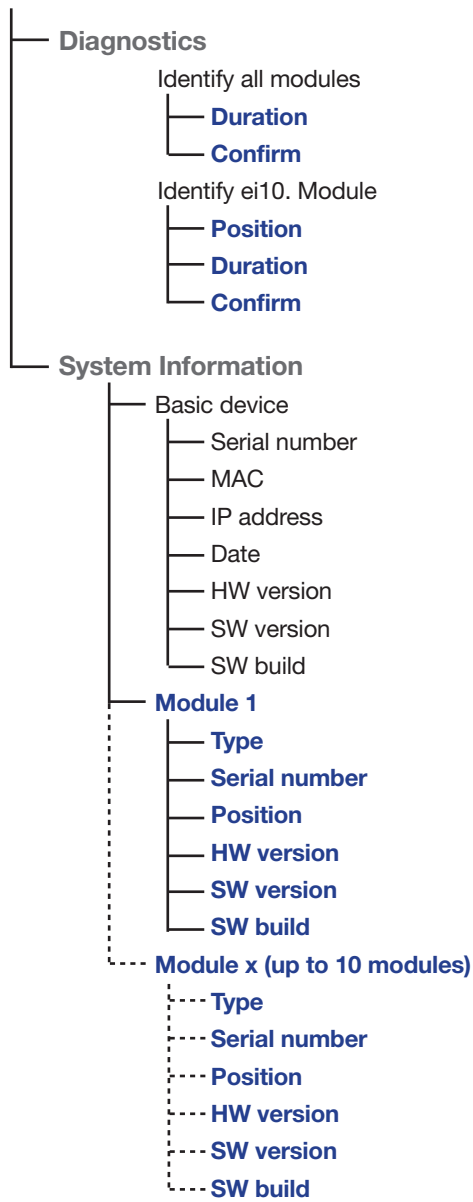

10. Module-relevant configurations

10.1 LP current transformer configuration on the basic device

In this user manual, the term "**current transformer**" is used for special transformers for the proportional conversion of currents of large amperages to directly measurable, smaller **current values**. In contrast, the term "**LP current transformer**" is used for special transformers for the proportional conversion of currents of large amperage to directly measurable, smaller **voltage values** (800-CT24 modules).

Current transformers and current sensors provide a safe galvanic isolation between the primary circuit and the measurement circuit due to their constructive design and their physical operating principle.

For simplification, basic devices use only the term "current transformer" in the display for the configuration of both "current transformers" and "LP current transformers".

i INFORMATION

Before configuring the LP current transformer ratios, be certain to connect the transformers in compliance with the specifications on the device rating plate and the technical data!

The following descriptions are based on the example of the UMG 801 as the basic device. The illustrations and descriptions may differ for other basic devices.

- Press function button 1 *ESC* to open the menu.
- Use buttons 2 "▲" and 5 "▼" to select the menu item *Configuration* and confirm with button 3 *Enter*.
- The *Configuration* window appears.
- In the *Configuration* window, use buttons 2 "▲" and 5 "▼" to select the menu item *Current transformers* and confirm with button 3 *Enter*.

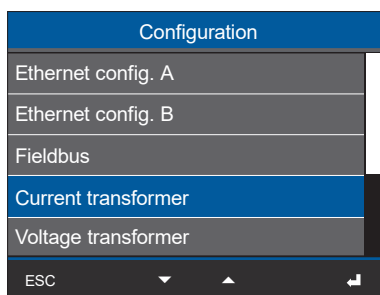

Fig. Window Configuration -> item Current transformer

- The *Current transformers* window appears.

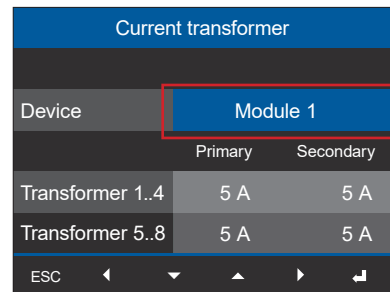

Fig. Window, Current transformers -> Selection of the module to be configured, e.g. Module 1

- In the *Current transformers* window, use buttons 2 "▲" and 5 "▼" to select the item *Basic device* and confirm with button 3 *Enter*.
- The item *Basic device* appears marked in "blue."
- Use buttons 2 "▲" and 5 "▼" to select the item for the module, e.g. *Module 1* and confirm with button 3 *Enter*.
- Use button 5 "▼" to go to the setting for the primary side of the LP current transformers 1-4 of the module (current measurement inputs I1..I4).
- The item for the primary side of the LP current transformers I1..I4 appears marked in "blue."
- Press button 3 *Enter*.
- The item for the primary side of the LP current transformers I1..I4 "blinks".
- Use buttons 4 (◀) and 6 (▶) to change the position of the digit to be set and buttons 2 (▲) and 5 (▼) to change the digit (-1/+1).
- Confirm your entries with button 3 *Enter* or end the action by pressing button 1 *ESC*.

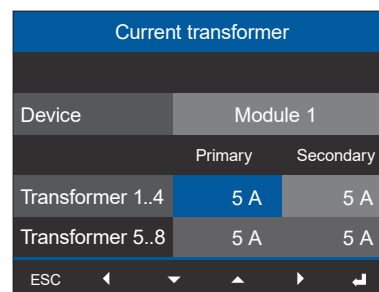

Fig. Window, Current transformer module 1 -> item, Primary for LP current transformers 1..4.

- Use button 6 (▶) to go to the configuration of the secondary side of the LP current transformers I1..I4 of the module.
- Configure the secondary side of the LP current transformers I1..I4 of the module in the same way (note here the "nominal voltage in mV" for the LP current transformers).

- Confirm your entries with button 3 *Enter* or end the action by pressing button 1 *ESC*.
- Use the function buttons to configure the **LP current transformer ratios 5-8 (15..18)** – primary and secondary side – of the module as described above.
- To return to the menu, confirm your entries with button 3 *Enter* or end the action by pressing button 1 *ESC*.

10.2 LP current transformer configuration in the GridVis software:

An assistant in the GridVis network visualization software helps with all module-relevant settings. Also note the usage information of the basic device.

i INFORMATION

You can also configure current and voltage transformer ratios in the device configuration of the **GridVis** software (see Fig. below). A description of the configuration can be found in the online help or in the tutorials for the software.

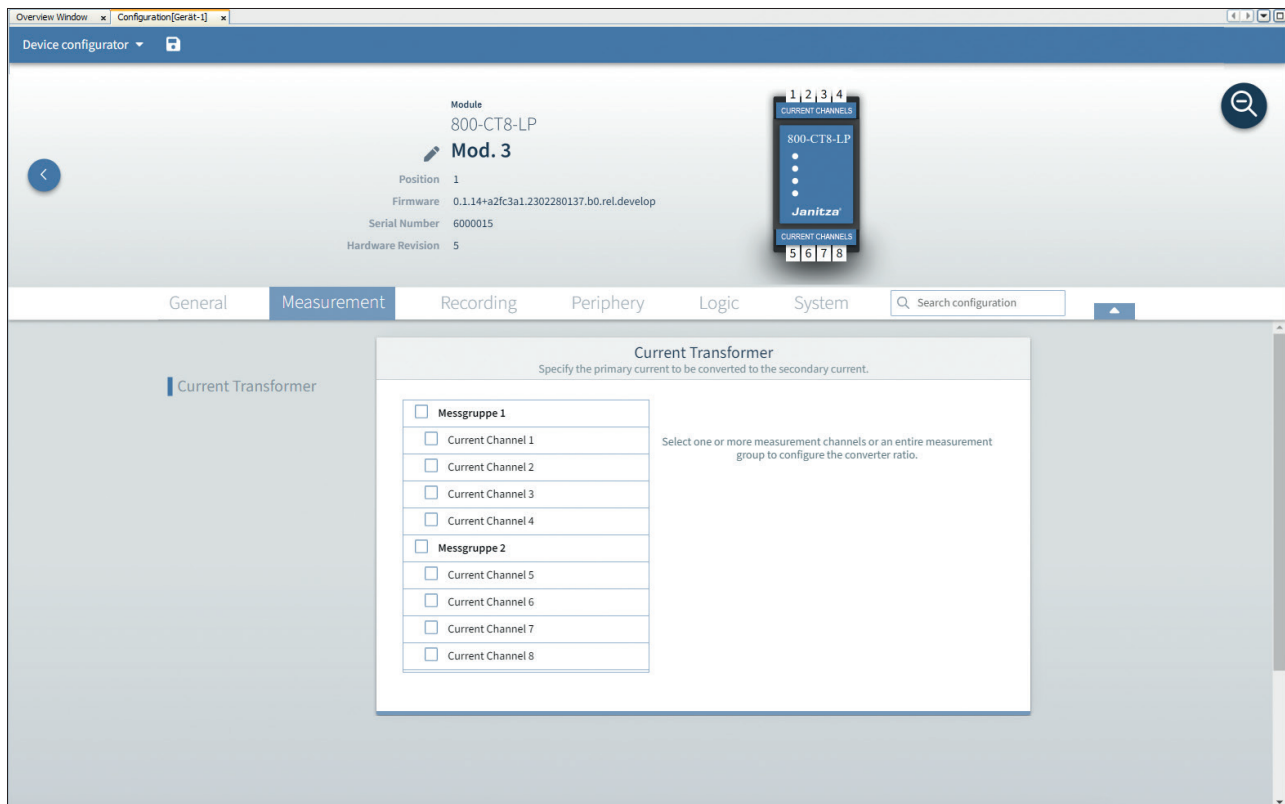

Fig. LP current transformer configuration "Module 1" (800-CT8-LP) in the GridVis software.

10.3 LP current transformer configuration via the device homepage of the basic device

Another option to configure the LP current transformers on the module may be available via the device homepage of the basic device.

i INFORMATION

All further descriptions of the device homepage can be found in the usage information for the basic device.

The screenshot shows the Janitza web interface. The 'Settings' menu item is highlighted with a red box. The 'Current transformer ratios' section is expanded, showing a dropdown menu with '1. Module 800-CT8-LP' selected and highlighted with a red box. Below this, there are two tables for channel configurations.

Channel 1 - 4		
Channel	Primär	Sekundär
1	5.00	333.00 mV Apply to module
2	5.00	333.00 mV
3	5.00	333.00 mV
4	5.00	333.00 mV

Channel 5 - 8		
Channel	Primär	Sekundär
5	5.00	333.00 mV
6	5.00	333.00 mV
7	5.00	333.00 mV

Fig. LP current transformer configuration "Module 1" (800-CT8-LP) using the example of the device homepage of the basic device.

11. Module-relevant measuring displays (module 800-CT8-LP only)

i INFORMATION

The following measured value and instrument displays of the basic device do not show a concrete application and may differ depending on the connection of your basic device with modules and the measuring environment!

- The permitted number of current measuring modules on a basic device can be found in “Tab. Suitable basic devices” on p. 2.
- You can change the names of the basic device, the modules or the measurement groups shown in the measurement device display using the device configuration of the GridVis software.
- The measurement device display shows the measurement group names with the respective position number of the module.
- Depending on the text length, measurement group names appear as scrolling text in the title line of the measurement device display.
- Further measured value and instrument displays can be found in the usage information for the basic device.

Menu (phasor diagram)

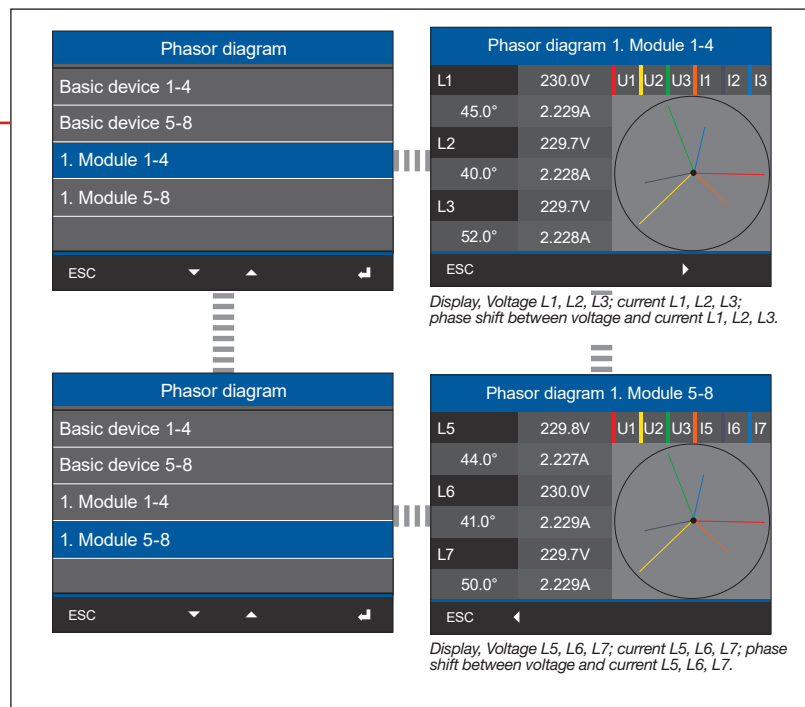
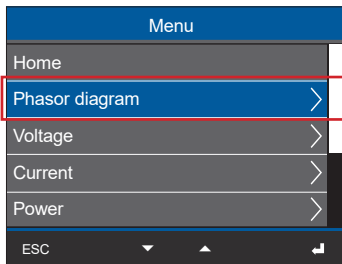

Menu (Current)

Menu	
Home	
Phasor diagram	>
Voltage	>
Current	>
Power	>
ESC	⏪ ⏩ ⏴ ⏵

Submenu (Current)

Current	
Current	>
THD I	>
ESC	⏪ ⏩ ⏴ ⏵

Submenu (THD-I)

Current	
Current	>
THD I	>
ESC	⏪ ⏩ ⏴ ⏵

Current			
Basic device 1-4			
Basic device 5-8			
1. Module 1-4			
1. Module 5-8			
ESC ⏪ ⏩ ⏴ ⏵			

Current Modul 1. Module 1-4			
	Value	Avg.	Max.
1	1.940A	1.940A	1.940A
2	1.940A	1.940A	1.940A
3	1.940A	1.940A	1.940A
4	0.001A	0.001A	0.001A
ESC ⏪ ⏩ ⏴ ⏵			

Display, Current (1-4) L1, L2, L3, L4 with mean and maximum values.

Current			
Basic device 1-4			
Basic device 5-8			
1. Module 1-4			
1. Module 5-8			
ESC ⏪ ⏩ ⏴ ⏵			

Current Modul 1. Module 5-8			
	Value	Avg.	Max.
5	1.930A	1.930A	1.930A
6	1.930A	1.930A	1.930A
7	1.930A	1.930A	1.930A
8	0.001A	0.001A	0.001A
ESC ⏪ ⏩ ⏴ ⏵			

Display, Current (5-8) L5, L6, L7, L8 with mean and maximum values.

THD-I			
Basic device 1-4			
Basic device 5-8			
1. Module 1-4			
1. Module 5-8			
ESC ⏪ ⏩ ⏴ ⏵			

THD-I 1. Module 1-4			
	Value	Avg.	Max.
1	166.3%	166.3%	166.3%
2	166.4%	166.4%	166.4%
3	166.4%	166.4%	166.4%
4	201.1%	207.0%	222.2%
ESC ⏪ ⏩ ⏴ ⏵			

Display, THD-I (1-4) - L1, L2, L3, L4 (Total Harmonic Distortion of the current in %) with average and maximum values.

THD-I			
Basic device 1-4			
Basic device 5-8			
1. Module 1-4			
1. Module 5-8			
ESC ⏪ ⏩ ⏴ ⏵			

THD-I 1. Module 5-8			
	Value	Avg.	Max.
5	166.3%	166.3%	166.3%
6	166.4%	166.4%	166.4%
7	166.4%	166.4%	166.4%
8	209.3%	212.3%	227.6%
ESC ⏪ ⏩ ⏴ ⏵			

Display, THD-I (5-8) - L5, L6, L7, L8 with mean and maximum values.

Menu (Power)

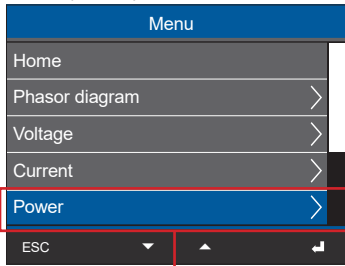

Submenu (Power summary)

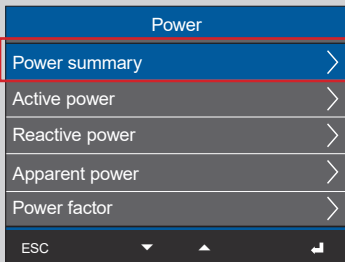

Power summary

- Basic device 1-4
- Basic device 5-8
- 1. Module 1-4**
- 1. Module 5-8
- ESC

Power summary 1. Module 1-4

	P	Q	S
1	0.10kW	-0.00kvar	0.19kVA
2	0.10kW	-0.00kvar	0.19kVA
3	0.10kW	-0.00kvar	0.19kVA
4	0.31kW	-0.00kvar	0.58kVA

Display, Summary of active, reactive and apparent power for L1, L2, L3 and their sum.

Power summary

- Basic device 1-4
- Basic device 5-8
- 1. Module 1-4
- 1. Module 5-8**
- ESC

Power summary 1. Module 5-8

	P	Q	S
5	0.11kW	-0.00kvar	0.20kVA
6	0.11kW	-0.00kvar	0.20kVA
7	0.11kW	-0.00kvar	0.20kVA
8	0.34kW	-0.00kvar	0.61kVA

Display, Summary of active, reactive and apparent power for L5, L6, L7 and their sum.

Submenu (Active power)

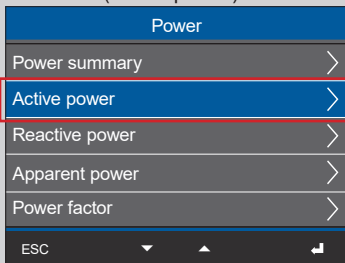

Active power

- Basic device 1-4
- Basic device 5-8
- 1. Module 1-4**
- 1. Module 5-8
- ESC

Active power 1. Module 1-4

	Value	Avg.
1	0.10kW	0.10kW
2	0.10kW	0.10kW
3	0.10kW	0.10kW
4	0.31kW	0.31kW

Display, Active power 1-4 for L1, L2, L3 with average values and sums.

Active power

- Basic device 1-4
- Basic device 5-8
- 1. Module 1-4
- 1. Module 5-8**
- ESC

Active power 1. Module 5-8

	Value	Avg.
5	0.11kW	0.11kW
6	0.11kW	0.11kW
7	0.11kW	0.11kW
8	0.34kW	0.34kW

Display, Active power 5-8 for L5, L6, L7 with average values and sums.

Submenu (Reactive power)

Power	
Power summary	>
Active power	>
Reactive power	>
Apparent power	>
Power factor	>
ESC	▼ ▲ ↵

Reactive power	
Basic device 1-4	
Basic device 5-8	
1. Module 1-4	
1. Module 5-8	
ESC	▼ ▲ ↵

Reactive power 1. Module 1-4		
	Value	Avg.
1	-0.02kvar	-0.01kvar
2	-0.02kvar	-0.01kvar
3	-0.02kvar	-0.01kvar
4	-0.06kvar	-0.02kvar
ESC	▼ ▲ ▶	

Display, Reactive power 1-4 for L1, L2, L3 with average values and sums.

Reactive power	
Basic device 1-4	
Basic device 5-8	
1. Module 1-4	
1. Module 5-8	
ESC	▼ ▲ ↵

Reactive power 1. Module 5-8		
	Value	Avg.
5	-0.02kvar	-0.01kvar
6	-0.02kvar	-0.01kvar
7	-0.02kvar	-0.01kvar
8	-0.06kvar	-0.03kvar
ESC	◀ ▼ ▲	

Display, Reactive power 5-8 for L5, L6, L7 with average values and sums.

Submenu (Apparent power)

Power	
Power summary	>
Active power	>
Reactive power	>
Apparent power	>
Power factor	>
ESC	▼ ▲ ↵

Apparent power	
Basic device 1-4	
Basic device 5-8	
1. Module 1-4	
1. Module 5-8	
ESC	▼ ▲ ↵

Apparent power 1. Module 1-4		
	Value	Avg.
1	0.19kVA	0.16kVA
2	0.19kVA	0.16kVA
3	0.19kVA	0.16kVA
4	0.58kVA	0.48kVA
ESC	▼ ▲ ▶	

Display, Apparent power 1-4 for L1, L2, L3 with average values and totals.

Apparent power	
Basic device 1-4	
Basic device 5-8	
1. Module 1-4	
1. Module 5-8	
ESC	▼ ▲ ↵

Apparent power 1. Module 5-8		
	Value	Avg.
5	0.20kVA	0.17kVA
6	0.20kVA	0.17kVA
7	0.20kVA	0.17kVA
8	0.61kVA	0.50kVA
ESC	◀ ▼ ▲	

Display, Apparent power 5-8 for L5, L6, L7 with average values and sums.

Submenu (Power factor)

Power	
Power summary	>
Active power	>
Reactive power	>
Apparent power	>
Power factor	>
ESC	⏏

Power factor		
Basic device 1-4		
Basic device 5-8		
1. Module 1-4		
1. Module 5-8		
ESC		

Power factor 1. Module 1-4		
	cos(phi)	Power factor
1	0.984	0.513
2	0.985	0.513
3	0.985	0.513
4	0.985	0.981
ESC		

Display, Power factor 1-4 for L1, L2, L3 with cos(phi) and sums.

Power factor		
Basic device 1-4		
Basic device 5-8		
1. Module 1-4		
1. Module 5-8		
ESC		

Power factor 1. Module 5-8		
	cos(phi)	Power factor
5	0.985	0.513
6	0.985	0.513
7	0.985	0.513
8	0.985	0.981
ESC		

Display, Power factor 5-8 for L5, L6, L7 with cos(phi) and sums.

Menu (Energy)

Menu	
Power	>
Energy	>
Drag pointer	>
Multifunctional channels	>
Digital I/O-Status	>
ESC	

Submenu (Active energy)

Energy	
Active energy	>
Reactive energy	>
Apparent energy	>
ESC	

Active energy		
Basic device 1-4		
Basic device 5-8		
1. Module 1-4		
1. Module 5-8		
ESC		

Active energy 1. Module 1-4		
Sum L1..L3		
Consumed	1.0kWh	
Delivered	1.0kWh	
ESC		

Display, Active energy 1-4, sum L1..L3, consumed and delivered.

Active energy		
Basic device 1-4		
Basic device 5-8		
1. Module 1-4		
1. Module 5-8		
ESC		

Active energy 1. Module 5-8		
Sum L1..L3		
Consumed	0.8kWh	
Delivered	0.8kWh	
ESC		

Display Active energy 5-8, sum L1..L3, consumed and delivered.

Submenu (Reactive energy)

Energy	
Active energy	>
Reactive energy	>
Apparent energy	>
ESC	

Submenu (Apparent energy)

Energy	
Active energy	>
Reactive energy	>
Apparent energy	>
ESC	

Reactive energy	
Basic device 1-4	
Basic device 5-8	
1. Module 1-4	
1. Module 5-8	
ESC	

Reactive energy 1. Module 1-4	
Sum L1..L3	
Inductive	0.9kvarh
Capacitive	0.9kvarh
ESC	

Display, Reactive energy 1-4, sum L1..L3, inductive and capacitive.

Reactive energy	
Basic device 1-4	
Basic device 5-8	
1. Module 1-4	
1. Module 5-8	
ESC	

Reactive energy 1. Module 5-8	
Sum L1..L3	
Inductive	0.4kvarh
Capacitive	0.4kvarh
ESC	

Display, Reactive energy 5-8, sum L1..L3, inductive and capacitive.

Apparent energy	
Basic device 1-4	
Basic device 5-8	
1. Modul 1-4	
1. Modul 5-8	
ESC	

Apparent energy 1. Modul 1-4	
Sum L1..L3	
Total	2.7kVAh
ESC	

Display, Apparent energy 1-4, sum L1..L3, total.

Apparent energy	
Basic device 1-4	
Basic device 5-8	
1. Modul 1-4	
1. Modul 5-8	
ESC	

Apparent energy 1. Modul 5-8	
Sum L1..L3	
Total	0.1kVAh
ESC	

Display, Apparent energy 5-8, sum L1..L3, total.

Menu (Configuration)

Menu	
Drag pointer	>
Multifunctional channels	>
Digital I/O-Status	>
Configuration	>
Diagnostics	>
ESC	

i INFORMATION

The description of the LP current transformer configuration of the modules can be found in chapter „10. Module-relevant configurations“ on page 34.

Menu (Diagnostics)

Menu	
Multifunctional channels	>
Digital I/O-Status	>
Configuration	>
Diagnostic	>
System information	>

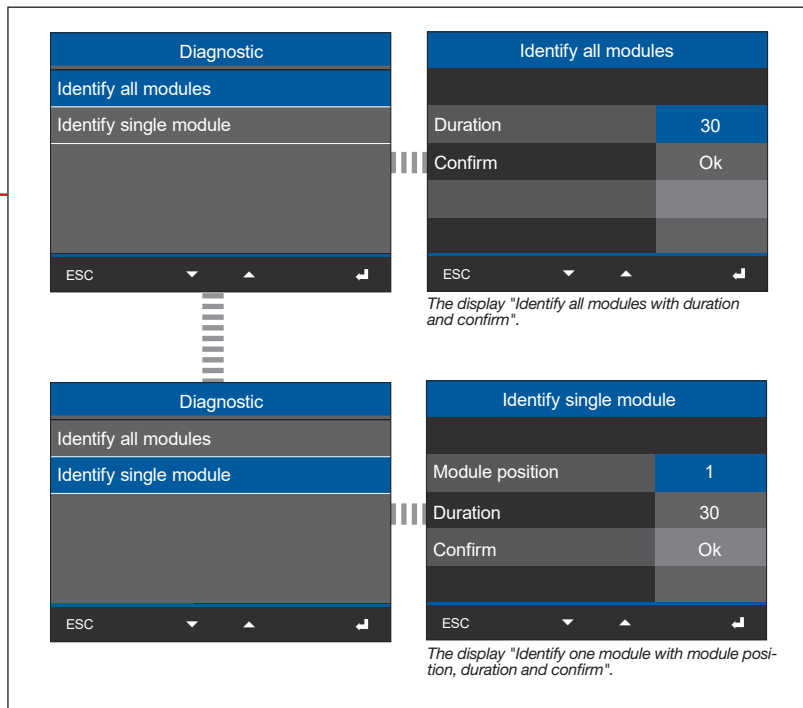

Menu (System information)

Menu	
Multifunctional channels	>
Digital I/O-Status	>
Configuration	>
Diagnostic	>
System information	>



12. Device views

- The views are for illustration purposes only and are not to scale.
- Dimensions in mm (in).

Front view

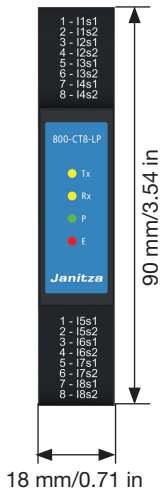

i INFORMATION

The dimensions of the device/module vary depending on the connection terminals used!

Bottom view



Top view



View from left

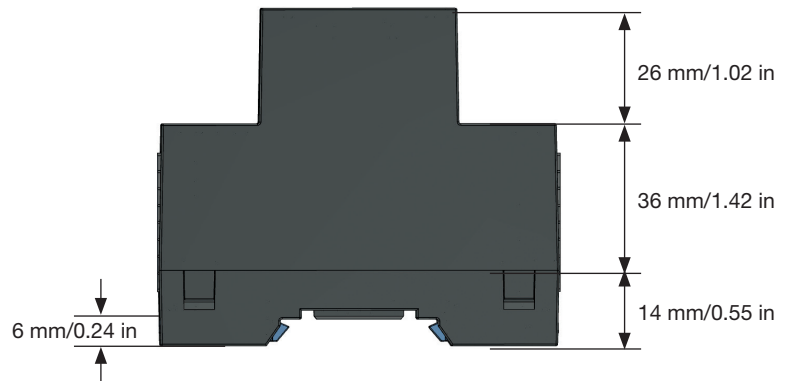

Rear view



Connector for the bus connector

Communication bus connector to the 800-CT8-LP module

Sockets for 800-CT8-LP module

Sockets for further modules

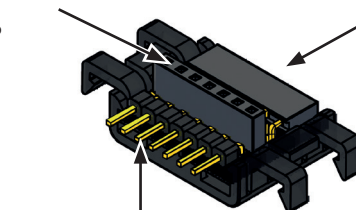

Contacts for the basic device or connected modules

13. Technical data

13.1 Technical specifications

General	
Net weight (with terminals)	approx. 73 g (0.16 lbs)
Device dimensions (without connection terminals)	W = 18 mm (w = 0.71 in), H = 90 mm (h = 3.54 in), D = 76 mm (d = 2.99 in)
Width of the device in horizontal pitches	1 HP (1 HP = 18 mm / 0.71 in)
Mounting orientation	As desired
Fastening/mounting - Suitable DIN rails - (35 mm / 1.38 in)	<ul style="list-style-type: none"> · TS 35/7.5 according to EN 60715 · TS 35/10 · TS 35/15 x 1.5
Protection against foreign matter and water	IP20 according to EN60529
Impact resistance	IK07 according to IEC 62262

Transport and storage	
The following specifications apply for devices transported and stored in the original packaging.	
Free fall	1 m (39.37 in)
Temperature	K55: -25 °C (-13 °F) to +70 °C (158 °F)
Relative humidity	0 to 95% at 25 °C (77 °F), no condensation

Environmental conditions during operation	
The module <ul style="list-style-type: none"> · Must only be operated with suitable basic devices (see "Tab. Suitable basic devices" on p. 2). · Is for weather-protected and stationary use. · Fulfills operating conditions according to DIN IEC 60721-3-3. · Has protection class II according to IEC 60536 (VDE 0106, part 1), a ground wire connection is not required! 	
Working temperature	-10 °C (14 °F) to +55 °C (131 °F)
Relative humidity	5 to 95% at 25 °C (77 °F), no condensation
Pollution degree	2
Ventilation	No forced ventilation required
Supply voltage	Via basic device

Current measurement	
Measurement via low-power current transformers with a secondary voltage of	0 - 400 mV
Channels	8 (2x4) <ul style="list-style-type: none"> · 2 systems - L1, L2, L3, N · Single channels
Input impedance per channel	230 kΩ
Nominal input signal of the module	0 .. 400 mV
Crest factor	1.8
Overload for 1 s	1 V
Resolution	16 bit
Sampling frequency	6.8 kHz
Frequency of the fundamental oscillation	40 Hz .. 70 Hz
Harmonics	1 ... 25 (odd only)

Interface and energy supply	
JanBus (proprietary)	· Via bus connector
Supply voltage (via JanBus interface)	24 V

Connection capacity of the terminals - Spring terminals (push-in terminals)	
Connectible conductors. Only connect one conductor per terminal point!	
Single core, multi-core, fine-stranded (min. - max.)	0.14 mm ² - 1.5 mm ² , AWG 26-16
Wire ferrules with collar * to DIN 46 228/4, (min. - max.)	0.25 mm ² - 1 mm ² , AWG 22-17
Wire ferrules without collar to DIN 46 228/1, (min. - max.)	0.25 mm ² - 1.5 mm ² , AWG 22-16
Wire ferrules: - Contact sleeve length ** - Strip length	8 - 12 mm (0.31 - 0.47 in) 10 - 12 mm (0.39 - 0.47 in)

* ... Applies to wire ferrules with a maximum plastic collar outer diameter of up to 4.5 mm (0.18 in).

**.. Depending on the type of wire ferrules used (wire ferrules manufacturer).

Module 800-CT8-LP LEDs	
Tx (send data)	Blink "orange" during operation and indicate cyclic data exchange.
Rx (receive data)	
P (power – power supply)	Lights "green" if the supply of power via the JanBus interface is correct.
E (error – initialization and malfunction)	Lights "red" when initializing/starting the device and in the event of a fault.

ⓘ INFORMATION

Detailed information on the functions and data of the basic device can be found in the usage information included with the basic device or available for download at www.janitza.com!

13.2 Performance characteristics of functions

Function	Symbol	Accuracy class - 333 mV nominal voltage	Display range
Total active power	P	0.5 (IEC61557-12)	0 .. 999 GW
Total reactive power	QA, Qv	1 (IEC61557-12)	0 .. 999 Gvar
Total apparent power	SA, Sv	0.5 (IEC61557-12)	0 .. 999 GVA
Total active energy	Ea	0.5 (IEC61557-12) 0.5S (IEC62053-22)	0 .. 999 GWh
Total reactive energy	ErA, ErV	1 (IEC61557-12)	0 .. 999 Gvarh
Total apparent energy	EapA, EapV	0.5 (IEC61557-12)	0 .. 999 GVAh
Phase current	I	0.2 (IEC61557-12)	0 .. 999 kA
Neutral conductor current calculated	INc	1.0 (IEC61557-12)	0.03 .. 999 kA
Power factor	PFA, PFV	1 (IEC61557-12)	0.00 .. 1.00
Current harmonics	Ih	Cl. 1 (IEC61000-4-7)	0 A .. 999 kA
THD of the current	THD _I	1.0 (IEC61557-12)	0 .. 999%

14. Dismounting

ATTENTION

Handling your module too roughly may cause damage to the module and result in material damage!

The bus connector contacts and the bottom bolts can be damaged or broken off when dismantling your module.

- **Never pull the module out of the DIN rail forcefully.**
- **First decouple the bus connectors (JanBus interface) and carefully unlock the bottom bolts of the module with a screwdriver!**

ATTENTION

Material damage due to disassembly or decoupling of the module during operation!

Dismounting or decoupling the module during communication with the basic device can cause damage to your devices!

- **Disconnect your system from the power supply prior to dismantling or disconnecting the module! Secure it against being switched back on! Check to be sure it is de-energized! Ground and short circuit! Cover or block off adjacent live parts!**

1. Disconnect the supply of power to the system! Secure it against being switched on! Check to be sure it is de-energized! Ground and short circuit! Cover or block off adjacent live parts!
2. Disconnect the wiring of your module.
3. Decouple the bus connectors (JanBus interface) of your module from the basic device and/or the connected modules by pulling out your module.
4. Unlock all bottom bolts of your module
Recommendation: Use a screwdriver (be careful!).
5. Remove your module from the DIN rail without touching or damaging the bus connector contacts.

i INFORMATION

Observe the following:

After dismantling the 800-CT8-LP module, the GridVis software deactivates the corresponding module! Information on this and further procedures can be found in the online help for the GridVis software.

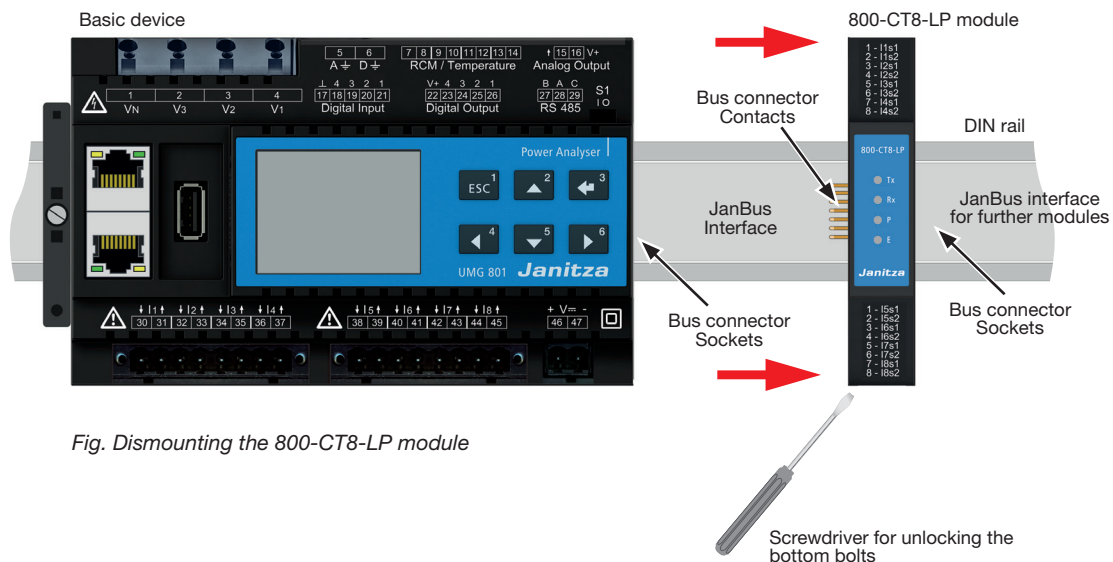

Fig. Dismounting the 800-CT8-LP module

15. Module exchange/error cases

Before replacing a module, please refer to Sect. "14. Dismounting" on p. 50 and "4. Mounting" on p. 18.

ATTENTION

Handling your module too roughly may cause damage to the module and result in material damage!

The bottom bolts and the bus connector contacts can be damaged or broken off when dismantling your module.

- **Never pull the module out of the DIN rail forcefully.**
- **Remove the module from the DIN rail without touching or damaging the bus connector contacts.**
- **First remove the connection terminals with the wiring and then carefully unlock the bottom bolts of the module with a screwdriver!**

ATTENTION

Material damage due to disassembly or decoupling of the modules during operation!

Dismounting or decoupling the modules during communication with the basic device can cause damage to your devices!

- **Disconnect your system from the power supply prior to dismantling or decoupling the modules! Secure it against being switched back on! Check to be sure it is de-energized! Ground and short circuit! Cover or block off adjacent live parts!**

INFORMATION

Observe the following:

After dismantling modules, the GridVis software deactivates the corresponding module! Information on this and further procedures can be found in the online help for the GridVis software.

15.1 Module replacement

A module must be exchanged, for example to replace a defective module with an intact module in your meter and module topology. The module replacement is carried out in the GridVis software.

On the basic device, you can recognize a defective module of your meter and module topology in the "Configuration" display. The defective module is **missing** in the "Configuration" display.

1. Remove the corresponding module as described in Sect. "14. Dismounting" on p. 50.
2. Replace a defective module, for example, with an intact one (see Sect. "4. Mounting" on p. 18).
3. Supply your meter and module topology (your system) with voltage.
4. Use the GridVis software ("Module exchange" function) to transfer data from a defective module (stored in the basic device) to the intact module.

INFORMATION

Please note before replacing a module! The "Module exchange" function in the GridVis software overwrites data records of exchanged modules in the memory of the basic device!

A description of the module exchange in the GridVis software can be found in the online help or the tutorials for the software.

15.2 Modules - Error cases

As already described in Sect. "7.3.3 Module identification - LED blink interval" on p. 27, the module has 4 LEDs.

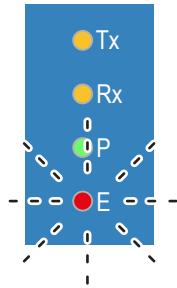

In the event of an error, the red LED (E) of the module blinks during operation at an interval of **0.5 s**.

After the definition of the error state there is a pause of **2 s** and the blink interval starts again from the beginning (repetition loop).

The number of blinks indicates the following error states:

Number of blinks	Error state
0	No error - normal operation.
1	Waiting for termination of the start pulse for the termination.
2	Waiting for response of the following module.
3	Waiting for start of addressing pulse
4	Waiting for the end of the addressing pulse.
5	Termination failed.
10	Application could not be started, module is still in the bootloader.

Tab.: Allocation of blink intervals/error state

Proceed as follows in the event of a module error:

1. Restart your meter and module topology (basic device: Menu > Configuration > System > Restart).
2. Check the connections and the fit of the devices, modules and components of your meter and module topology while complying with the safety rules!

⚠ WARNING

Risk of injury due to electrical current and voltage!

Severe bodily injury or death can result! Therefore please abide by the following:

- **Do not touch bare, stripped wires or device inputs that are dangerous to touch on the devices, components and modules.**
- **Switch off your installation before commencing work! Secure it against being switched on! Check to be sure it is de-energized! Ground and short circuit! Cover or block off adjacent live parts!**

3. If these measures are unsuccessful, please contact our support team (www.janitza.com)!

16. Service and maintenance

Prior to outbound delivery, your device (module/component) is subjected to various safety tests and is marked with a seal. If a device (module/component) is opened, the safety tests must be repeated. The warranty is only valid for unopened devices (modules/components).

16.1 Repair

Repairs can only be carried out by the manufacturer.

16.2 Service

If questions arise which are not described in this user manual, please contact the manufacturer.

To answer your questions, it is essential that you provide the following information:

- Device designation (see rating plate).
- Serial number (see rating plate).
- Hardware version (see system display).
- Software release (see system display).
- Measured voltage and supply voltage.
- An exact error description.

16.3 Device adjustment

Devices (components/modules) are adjusted by the manufacturer prior to outbound delivery. No readjustment is required when the environmental conditions are complied with.

16.4 Calibration interval

A recalibration is recommended after about 5 years. Contact the manufacturer or an accredited laboratory for calibration.

16.5 Firmware update

A firmware update of the basic device and the module can be done

1. via the device homepage of the basic device (menu "Settings -> Firmware update" - see usage information for the basic device).
2. via the firmware update wizard of the GridVis software:
 - Open the Firmware Update Assistant in the GridVis software by clicking "Update device" in the "Extras" menu.
 - Select a corresponding update file and carry out the update.

INFORMATION

This user manual describes the modules and provides information on the operation of the modules via the basic device.

In addition to this user manual, refer to the usage information for your basic device, such as:

- User manual
- Installation manual
- Safety information
- Data sheet
- Installation supplement

In addition, also note any special usage information for your application/project!

Moreover, the **GridVis** software has an "online help" feature.

16.6 Procedure in the event of a malfunction

ATTENTION

An error in the communication with the basic device leads to a device fault!

If communication from the basic device to the modules is lacking or faulty during operation, a warning signal will appear on the display of the basic device.

Prior to dismantling or disconnecting the modules of the basic device (the system)

- **Disconnect the supply of power! Secure it against being switched on! Check to be sure it is de-energized! Ground and short circuit! Cover or block off adjacent live parts!**
- **Prior to remounting, it may be necessary to restart the basic device.**
- **Also take note of the chapter "Procedure in the event of a malfunction" in the documentation of your basic device.**
- **If the measures indicated here are unsuccessful, please contact our support team (www.janitza.com).**
- **If there is discernible damage, send the device, component or module back to the manufacturer in compliance with proper transport conditions.**

16.7 Reset to factory settings

The "Reset to factory settings" function must be carried out via the basic device. A description of this can be found in the user manual for the basic device.

16.8 Information on saving measured values and configuration data

INFORMATION

The basic device stores the following measured values every 5 minutes at the latest:

- Min. / max. / average values
- Energy values (work values)

The basic device saves configuration data immediately!

Janitza

Janitza electronics GmbH
Vor dem Polstück 6 | 35633 Lahnau
Germany

Tel. +49 6441 9642-0
info@janitza.com | www.janitza.com